



Electrolux
PROFESSIONAL

**Modular Cooking Range Line
thermaline 85 - 4 Zone Full Surface
Induction Top on Open Base, 1 Side,
Backsplash**

ITEM # _____

MODEL # _____

NAME # _____

SIS # _____

AIA # _____



588660
(MBJJGBJ1AO)

Full Surface Induction Top on Open Base, 4 zones, one-side operated with backsplash

Short Form Specification

Item No. _____

Unit constructed according to DIN 18860_2 with 20 mm drop nose top and 70 mm recessed plinth. Internal frame for heavy duty sturdiness in stainless steel. 2 mm top in 1.4301 (AISI 304). Flat surface construction, easily cleanable. THERMODUL connection system enables seamless worktop when units are connected and avoids soil penetrating. Large multi-coil glass ceramic surface without any "dead" spots allows for quick and easy cleaning. Features 9 power levels with fast deployment to full heating power and very low heat dissipation to kitchen. Overheat protection switches off the supply in case of overheating. Metal knobs with embedded hygienic silicon "soft" grip enable easier handling and cleaning. IPX5 water resistance certification.
Configuration: Freestanding, one side operated with backsplash, on open base.

Main Features

- Almost the entire surface of the ceramic plate can be used without "dead" spots.
- Fast deployment with full heating power immediately.
- Low heat dissipation to the kitchen.
- Overheat protection: the temperature sensor switches off the supply in case of overheating.
- Pans can easily be moved from one area to another without lifting.
- The large surface multi-coil induction top offers a substantial increase in pan and pot capacity thanks to the seamless transition between individual heating zones, ideal for à la carte operation.
- The smooth glass-ceramic surface can be quickly and easily cleaned, thus providing maximum hygiene.
- All major components may be easily accessed from the front.
- THERMODUL connection system creates a seamless work top when units are connected to each other thus avoiding soil penetrating vital components and facilitating the removal of units in case of replacement or service.
- Metal knobs with embedded hygienic "soft-touch" grip for easier handling and cleaning. The special design of the controls prevents infiltration of liquids or soil into vital components.
- 9 power levels.
- Handles are ergonomically designed with silicon "soft" grip for easy handling and cleaning.

Construction

- Control light for each zone.
- 2 mm top in 1.4301 (AISI 304).
- Unit constructed according to DIN 18860_2 with 20 mm drop nose top and 70 mm recessed plinth.
- Flat surface construction with minimal hidden areas to easily clean all surfaces
- IPX5 water resistance certification.
- Internal frame for heavy duty sturdiness in stainless steel.

Sustainability



- This model is compliant with Swiss Energy Efficiency Ordinance (730.02).

APPROVAL: _____



Experience the Excellence
www.electroluxprofessional.com

Optional Accessories

- | | | | | | |
|--|------------|--------------------------|---|------------|--------------------------|
| • Scraper for cook tops | PNC 910601 | <input type="checkbox"/> | • Stainless steel dividing panel, 850x700mm, (it should only be used between Electrolux Professional thermaline Modular 85 and thermaline C85) | PNC 913670 | <input type="checkbox"/> |
| • Connecting rail kit for appliances with backsplash, 850mm | PNC 912498 | <input type="checkbox"/> | • Stainless steel side panel, 850x700mm, flush-fitting (it should only be used against the wall, against a niche and in between Electrolux Professional thermaline and ProThermetic appliances and external appliances - provided that these have at least the same dimensions) | PNC 913686 | <input type="checkbox"/> |
| • Portioning shelf, 1000mm width | PNC 912528 | <input type="checkbox"/> | | | |
| • Portioning shelf, 1000mm width | PNC 912558 | <input type="checkbox"/> | | | |
| • Folding shelf, 300x850mm | PNC 912579 | <input type="checkbox"/> | | | |
| • Folding shelf, 400x850mm | PNC 912580 | <input type="checkbox"/> | | | |
| • Fixed side shelf, 200x850mm | PNC 912586 | <input type="checkbox"/> | | | |
| • Fixed side shelf, 300x850mm | PNC 912587 | <input type="checkbox"/> | | | |
| • Fixed side shelf, 400x850mm | PNC 912588 | <input type="checkbox"/> | | | |
| • Stainless steel front kicking strip, 1000mm width | PNC 912636 | <input type="checkbox"/> | | | |
| • Stainless steel side kicking strip left and right, wall mounted, 850mm width | PNC 912659 | <input type="checkbox"/> | | | |
| • Stainless steel side kicking strip left and right, back-to-back, 1700mm width | PNC 912662 | <input type="checkbox"/> | | | |
| • Stainless steel plinth, against wall, 1000mm width | PNC 912884 | <input type="checkbox"/> | | | |
| • Stainless steel side panel, 850x700mm, right side, against wall | PNC 913003 | <input type="checkbox"/> | | | |
| • Stainless steel side panel, 850x700mm, left side, against wall | PNC 913004 | <input type="checkbox"/> | | | |
| • Back panel, 1000x700mm, for units with backsplash | PNC 913015 | <input type="checkbox"/> | | | |
| • Endrail kit, flush-fitting, with backsplash, left | PNC 913115 | <input type="checkbox"/> | | | |
| • Endrail kit, flush-fitting, with backsplash, right | PNC 913116 | <input type="checkbox"/> | | | |
| • Endrail kit (12.5mm) for thermaline 85 units with backsplash, left | PNC 913206 | <input type="checkbox"/> | | | |
| • Endrail kit (12.5mm) for thermaline 85 units with backsplash, right | PNC 913207 | <input type="checkbox"/> | | | |
| • U-clamping rail for back-to-back installations with backsplash (to be ordered as S-code) | PNC 913226 | <input type="checkbox"/> | | | |
| • Insert profile, d=850mm | PNC 913231 | <input type="checkbox"/> | | | |
| • Perforated shelf for warming cabinets and cupboard bases (one-side operated TL80-85-90 and two-side operated for TL80) | PNC 913234 | <input type="checkbox"/> | | | |
| • Side reinforced panel only in combination with side shelf, for against the wall installations, right | PNC 913261 | <input type="checkbox"/> | | | |
| • Side reinforced panel only in combination with side shelf, for against the wall installations, left | PNC 913262 | <input type="checkbox"/> | | | |
| • Shelf fixation for TL80-85-90 one-side operated, TL80 two-side operated | PNC 913281 | <input type="checkbox"/> | | | |

Front

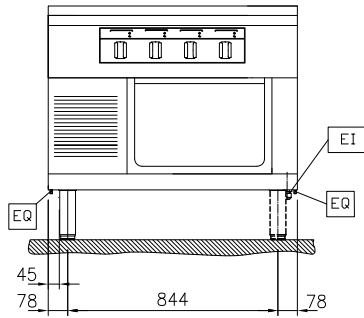

Side

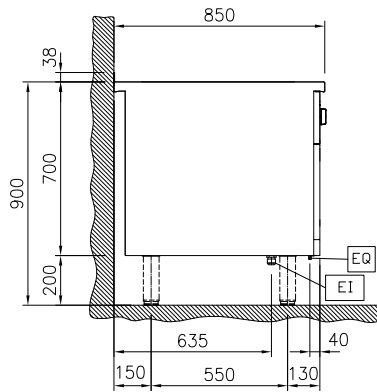

EI = Electrical inlet (power)
 EQ = Equipotential screw

Top

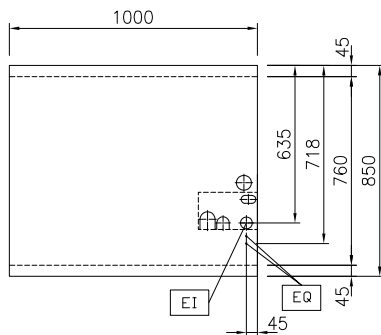
Electric

Supply voltage: 400 V/3N ph/50/60 Hz
 Total Watts: 28 kW

Key Information:

External dimensions, Width: 1000 mm
 External dimensions, Depth: 850 mm
 External dimensions, Height: 700 mm
 Storage Cavity Dimensions (width): 580 mm
 Storage Cavity Dimensions (height): 330 mm
 Storage Cavity Dimensions (depth): 740 mm
 Net weight: 118 kg

Configuration: On Base; One-Side Operated
 Front Plates Power: 7 - 7 kW
 Back Plates Power: 7 - 7 kW
 Front Plates dimensions: 420x370 420x370
 Back Plates dimensions: 420x370 420x370

Sustainability

Current consumption: 43 Amps